

Loctek

AUDIO & VISUAL SOLUTIONS



2023/24

DNA[®]
DESIGNER AUDIO

**SUPPORTS FOR TV, PROJECTOR,
COMPUTER MONITORS & OTHER
AV EQUIPMENT.**

loctek.com.au

Loctek manufactures a wide range of innovative mounts for all applications. Whilst home entertainment is a large market we have not limited ourselves our mounts are designed for use in the following applications:

Home Entertainment Perfect for improving the viewing experience in your home. Loctek have a solution for every screen size from smaller screens right up to large screens. Loctek mounts are perfect for every room in the home from the lounge room, bedroom, kitchen, study and even the bathroom. Ideal for use in Apartments, homes, aged care, mining accommodation and any other type of home, Loctek mounts create increased flexibility and viewing options and are elegantly designed to provide a modern look in your home.

Business & Commercial Ideal mounting solutions for businesses in corporate, commercial and boardroom applications where the utilisation and installation of mounts through the office creates efficient use of your office space. Correct positioning and installation of screens and monitors also helps address occupational health and safety issues in the workplace.

Hospitality Mounting solutions for hotel and motel guest rooms, VIP suites, gaming floors, sports clubs, restaurants and night clubs, Loctek mounts are easy to install, aesthetically pleasing, secure, reliable and versatile. Mounting solutions that simply look great and fit perfectly.

Education Ideal mounting solutions for classrooms, auditoriums, cafeterias, gymnasiums etc. Loctek provides teachers and instructors with solutions for flat panel and projector mounting to make education easier and more enjoyable.

Digital Signage Mounting solutions for interactive displays in stores and restaurants, point of sale displays (POS), trade shows, information kiosks in common areas, or anywhere where information needs to be displayed. Having important information in plain sight is critical for so many businesses. Locteks range of mounts can be used virtually anywhere so that important information is in plain sight at all times.

Security Ideal mounting solutions for security applications. Monitoring and safeguarding important materials and property requires always having a perfect view of every area of the premises. Loctek offer solutions for screen mounts which are ideal for the security market. Designed to keep everything in plain and easy sight while saving space in tight areas.

Professional AV Mounting solutions for A/V and broadcast professionals where reliability and function are paramount. Loctek work extensively with Pro A/V installers to find out what they need, and then provide them with a wide selection of mounting options to meet their needs and requirements.

OEM Loctek is a leading supplier of mounting solutions worldwide. Loctek work together with original equipment manufacturers (OEM) to develop versatile mounting products and solutions for the latest display technologies as they emerge in the worldwide market. These relationships enable Loctek to stay at the forefront of the market with innovative, functional, reliable, and flexible mounting solutions.

Mounting Functions The range of Loctek mounts have been categorised and colour coded for easy reference.



Let's share the life!

Full Motion Mounts

Page
4-7

Tilt Mounts

Page
8-10

Fixed Mounts

Page
11-13

Ceiling Mounts

Page
14-16

Projector Mounts

Page
17-18

Desk Top Mounts

Page
19-21

Wall Furniture

Page
22

Mounting Standards Loctek mounts support the worldwide VESA standard for mounting flat panel screens. This VESA standard outlines and specifies the exact placement of the mounting holes on the back of the screen where the mount attaches to. There are many VESA monitor mounting size configurations such as 75mm x 75mm, 100mm x 100mm, 200mm x 200mm as examples.

Please ensure that you take care when matching the correct VESA size on the back of the screen with the mount. Always pay attention to the weight capability of the mount and ensure that the wall or mounting surface must be capable of supporting the combined weight of the mount and the display, otherwise the structure must be reinforced.

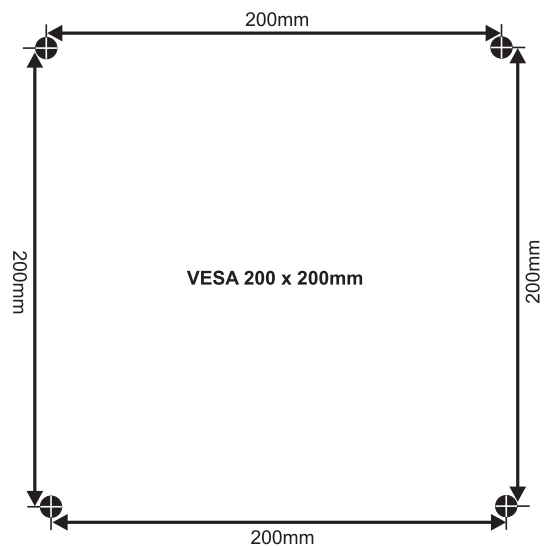
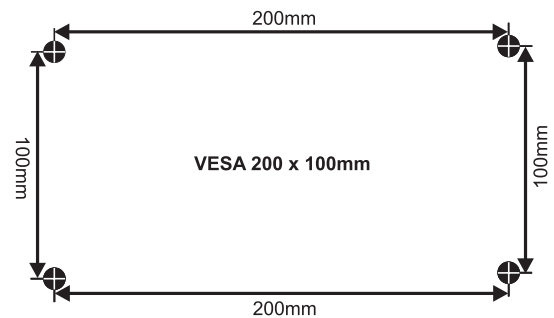
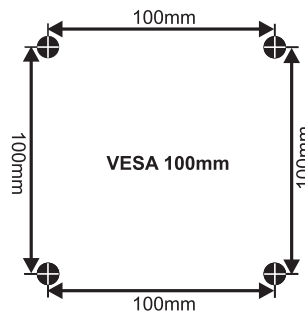
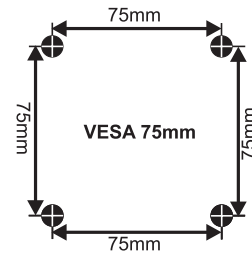



Full Motion Mounts

Loctek Full Motion mounts are designed to extend, retract, tilt and swivel in all directions. These flexible mounts are the ideal choice for most households due to their versatility. A full motion mount is recommended when multiple viewing positions are desired or when room shape or window location makes it difficult to properly position the screen. These mounts find the perfect angle for comfortable viewing without eye or neck strain.

Full Motion Mounts

PSW955M 37" to 60" Full Motion Mount Up to 45kg

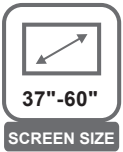

37"-60"

SCREEN SIZE



400x400

VESA



50-465mm

WALL DISTANCE



45°

ADJUST



-2°
12°

ADJUST



Max

45Kgs

WEIGHT



3 Pcs

CARTON QTY

Allows maximum flexibility — extend, tilt and swivel, providing easy viewing from any seat in a room.

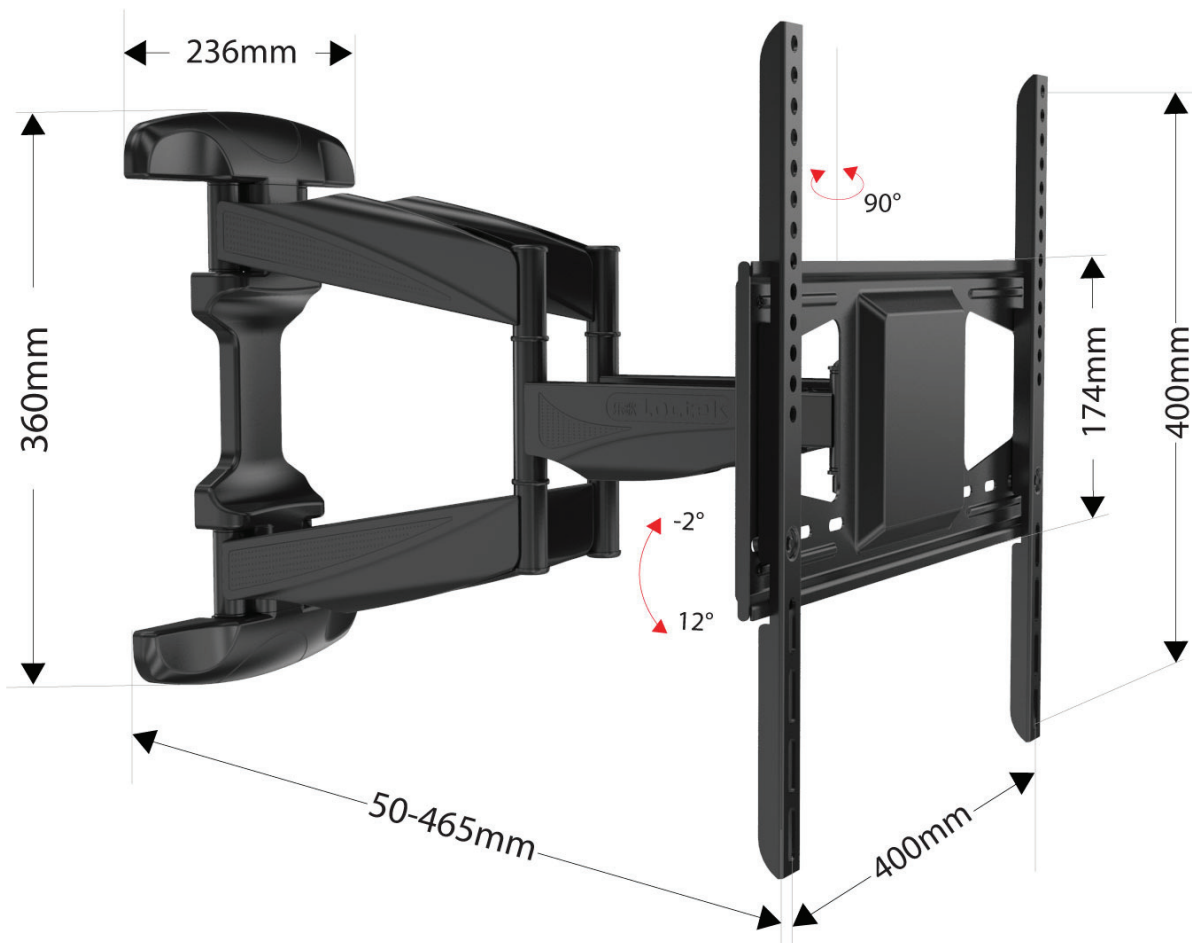

Full Motion Mounts

PSW792LAT 47" to 90" Full Motion Mount Up to 60kg



SCREEN SIZE



VESA



WALL DISTANCE

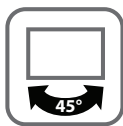

ADJUST



ADJUST



WEIGHT

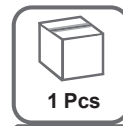

CARTON QTY

Allows maximum flexibility — extend, tilt and swivel, providing easy viewing from any seat in a room.

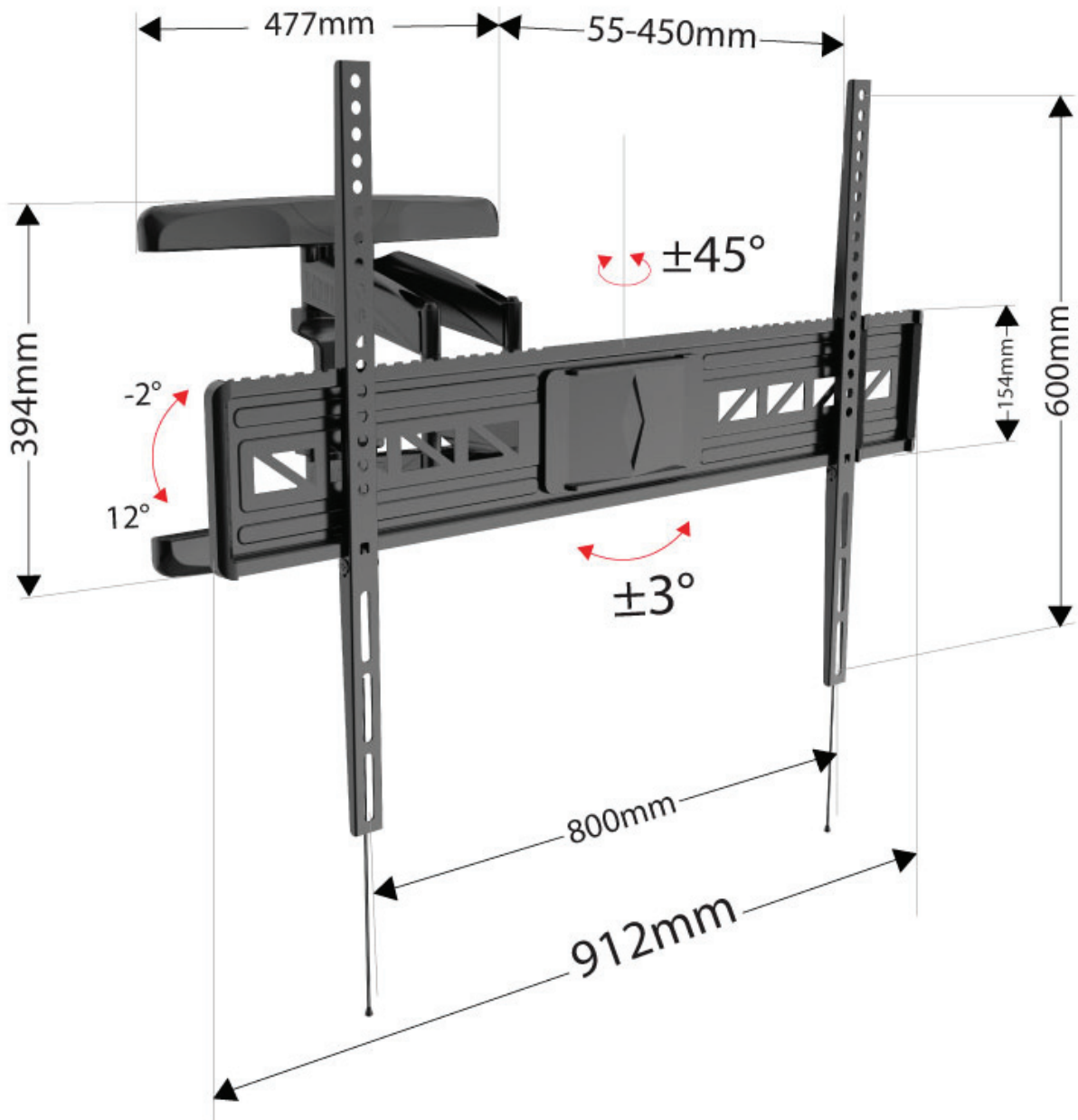

Full Motion Mounts

PSW652M 17" to 42" Full Motion Mount Up to 25kg

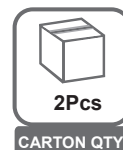
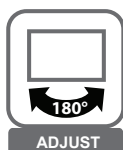
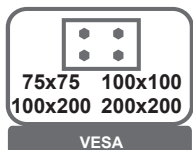

Allows maximum flexibility — extend, tilt and swivel, providing easy viewing from any seat in a room.

VESA (Additional): 100x100mm/100x200mm/200x200mm
(Without the horizontal & vertical arms)

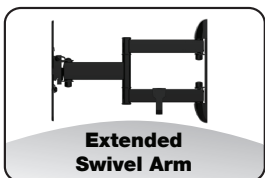
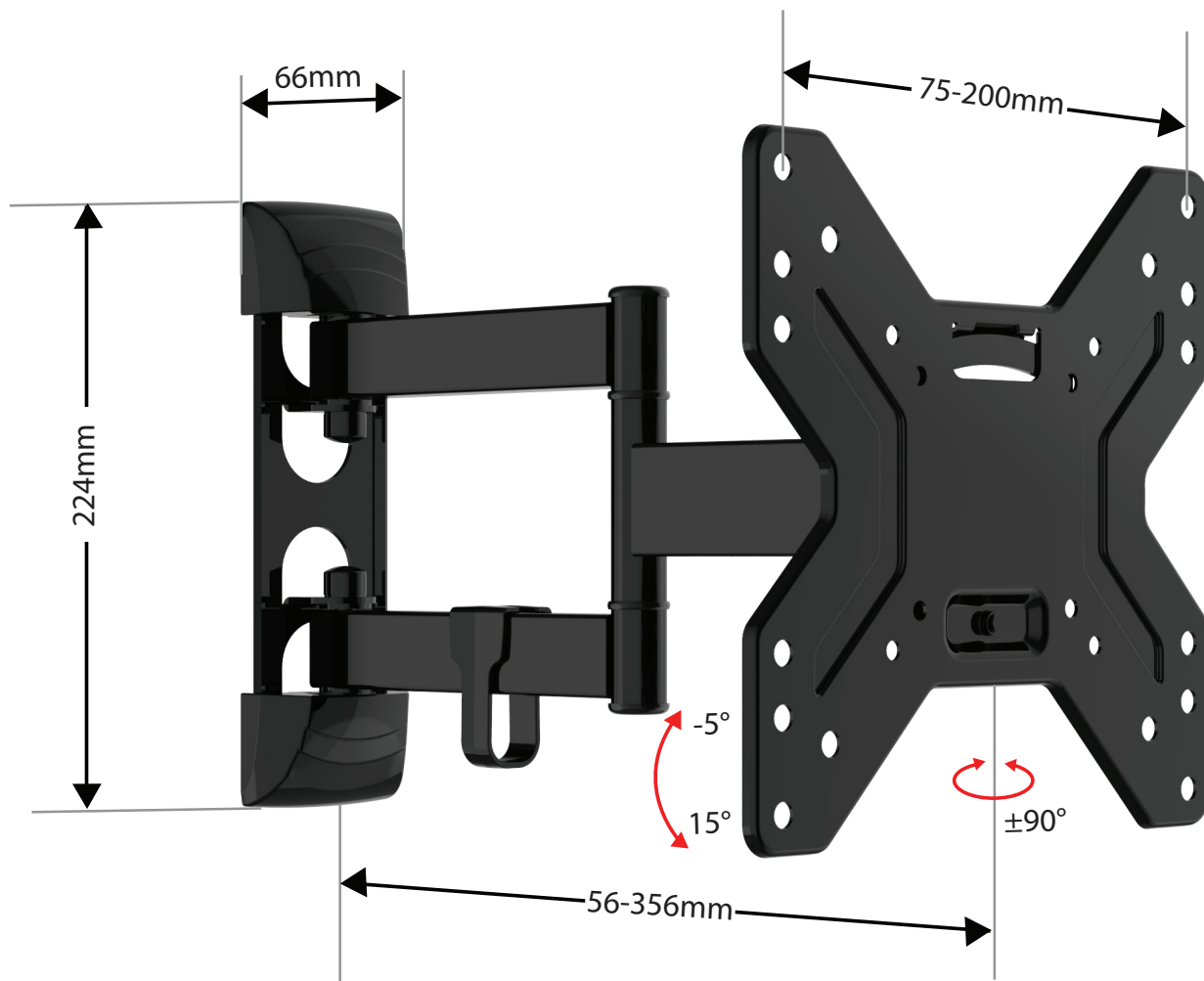



Tilt Mounts

Loctek Tilt Mounts are designed to tilt downwards for better viewing from the couch, bed or even floor. Loctek Tilt Mounts are ideal for areas where reflections from windows or lighting interfere with TV viewing or when multiple viewing angles are desired. These mounts find the perfect angle for comfortable viewing without eye or neck strain.

PSW791T

47" to 90" Tilt Mount Up to 60kg

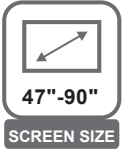

Designed to tilt downwards for better viewing from the couch, bed or even floor.



Tilt Mounts

PSW698MT 32" to 65" Tilt Mount Up to 35kg

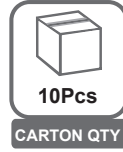
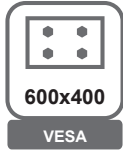

Designed to tilt downwards for better viewing from the couch, bed or even floor.

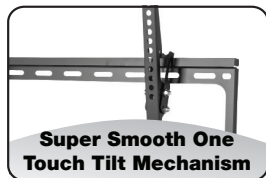
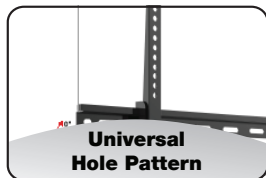
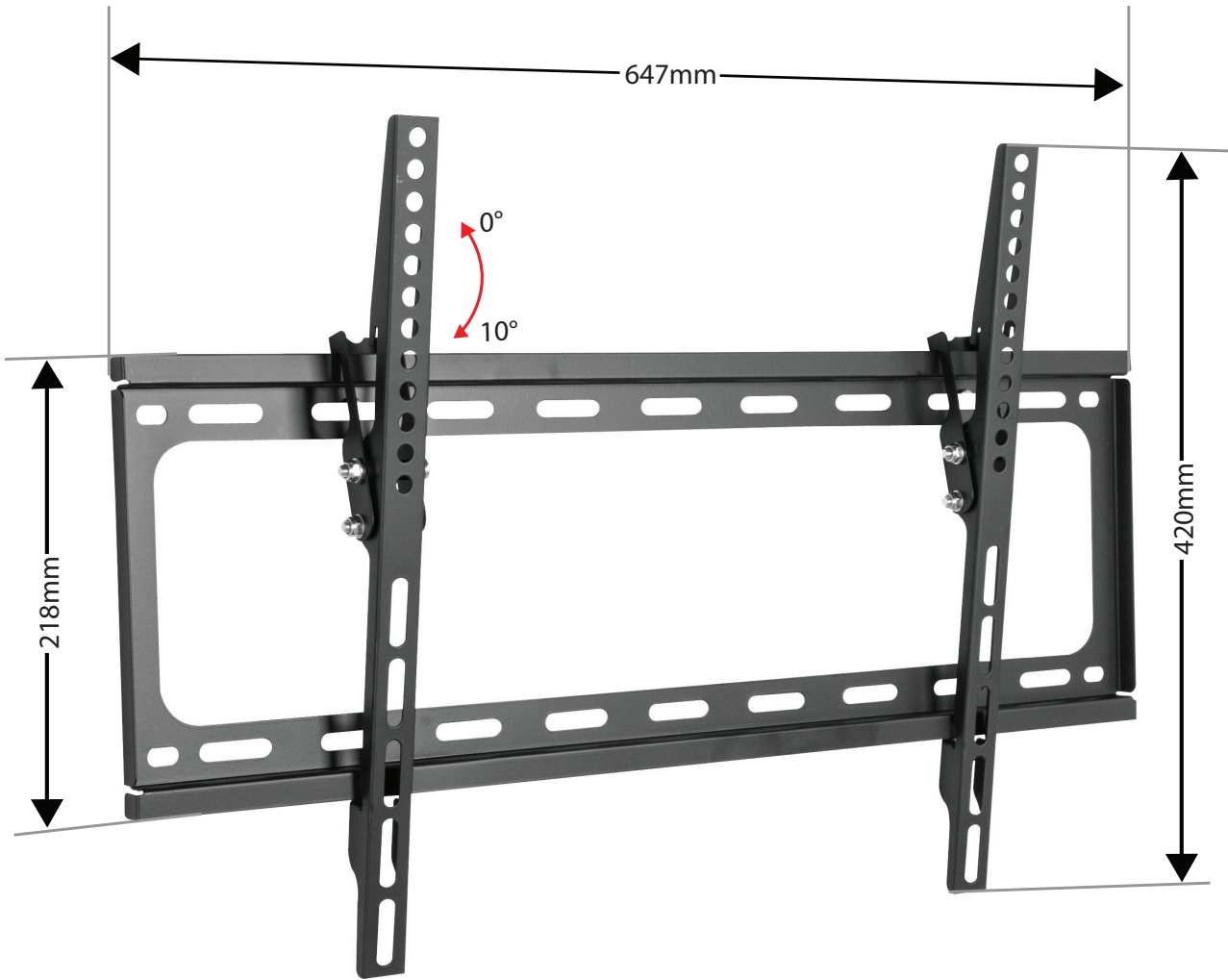

6 948530 110841

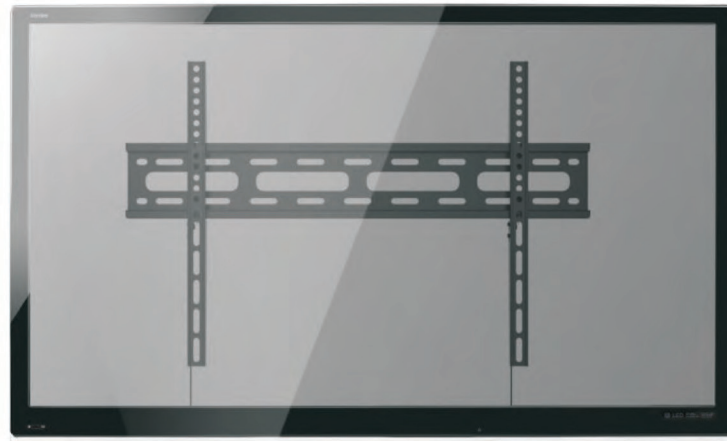

Fixed Mounts

Loctek Fixed Mounts are designed to mount the screen as close to the wall as possible to maximize the sleek low profile lines of flat panel screens. Loctek Fixed Mounts are recommended for applications where the screen is to be positioned at a fixed height and where seating and viewing is within the ideal viewing angle range of the screen.

Fixed Mounts

PSW793LF

47" to 100" Fixed Mount Up to 75kg

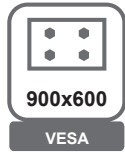

Allows screens to be mounted as close to the wall as possible to maximize the low profiles of flat panel screens.

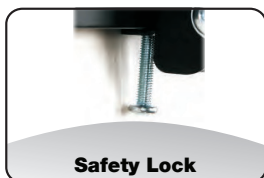
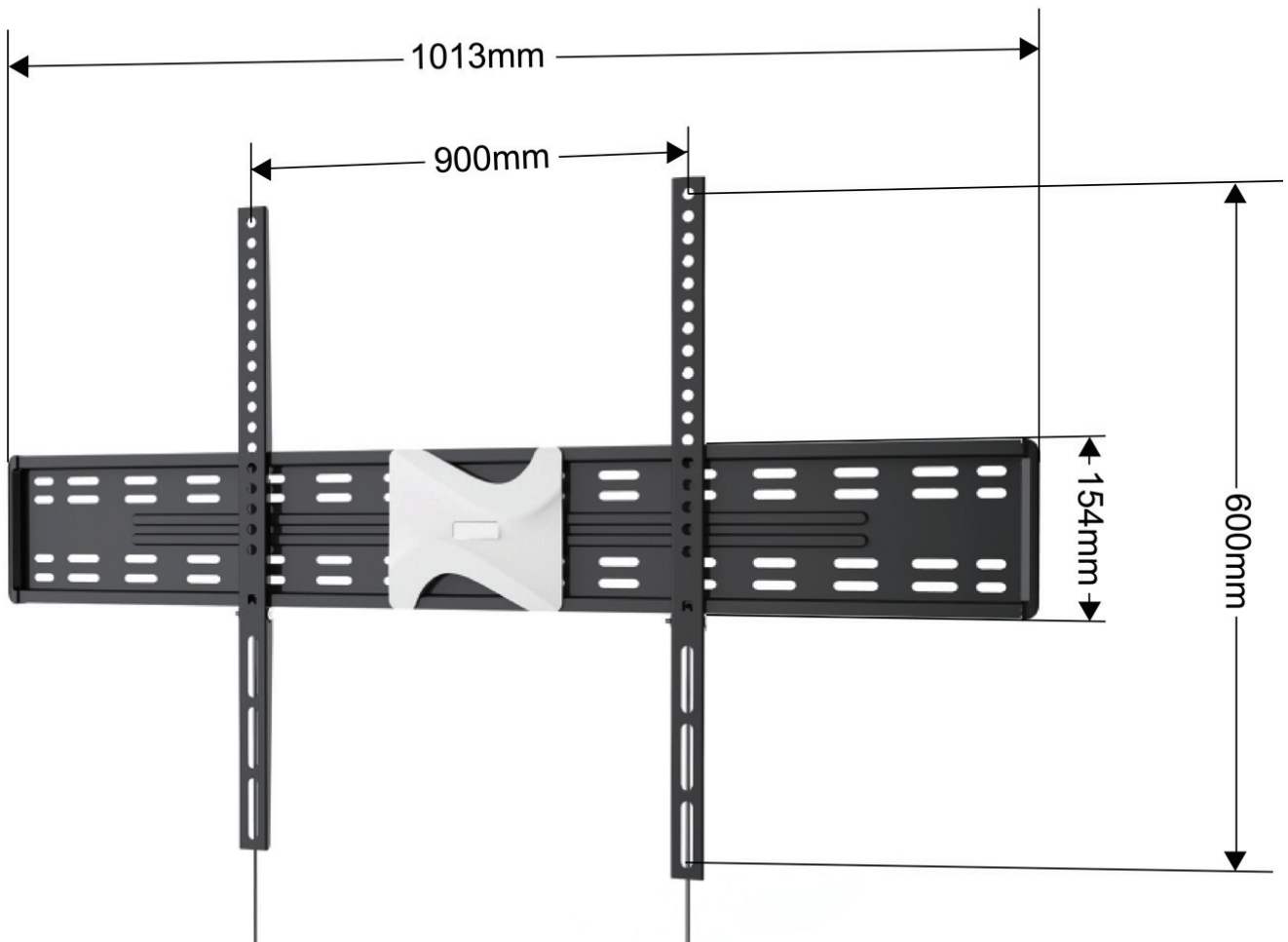

Fixed Mounts

PSW596MF

32" to 65" Fixed Mount Up to 35kg



32"-65"

SCREEN SIZE

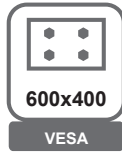

600x400

VESA

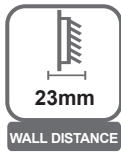

23mm

WALL DISTANCE



35Kgs

WEIGHT



10Pcs

CARTON QTY

Allows screens to be mounted as close to the wall as possible to maximize the low profiles of flat panel screens.

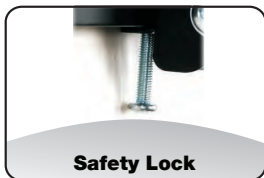
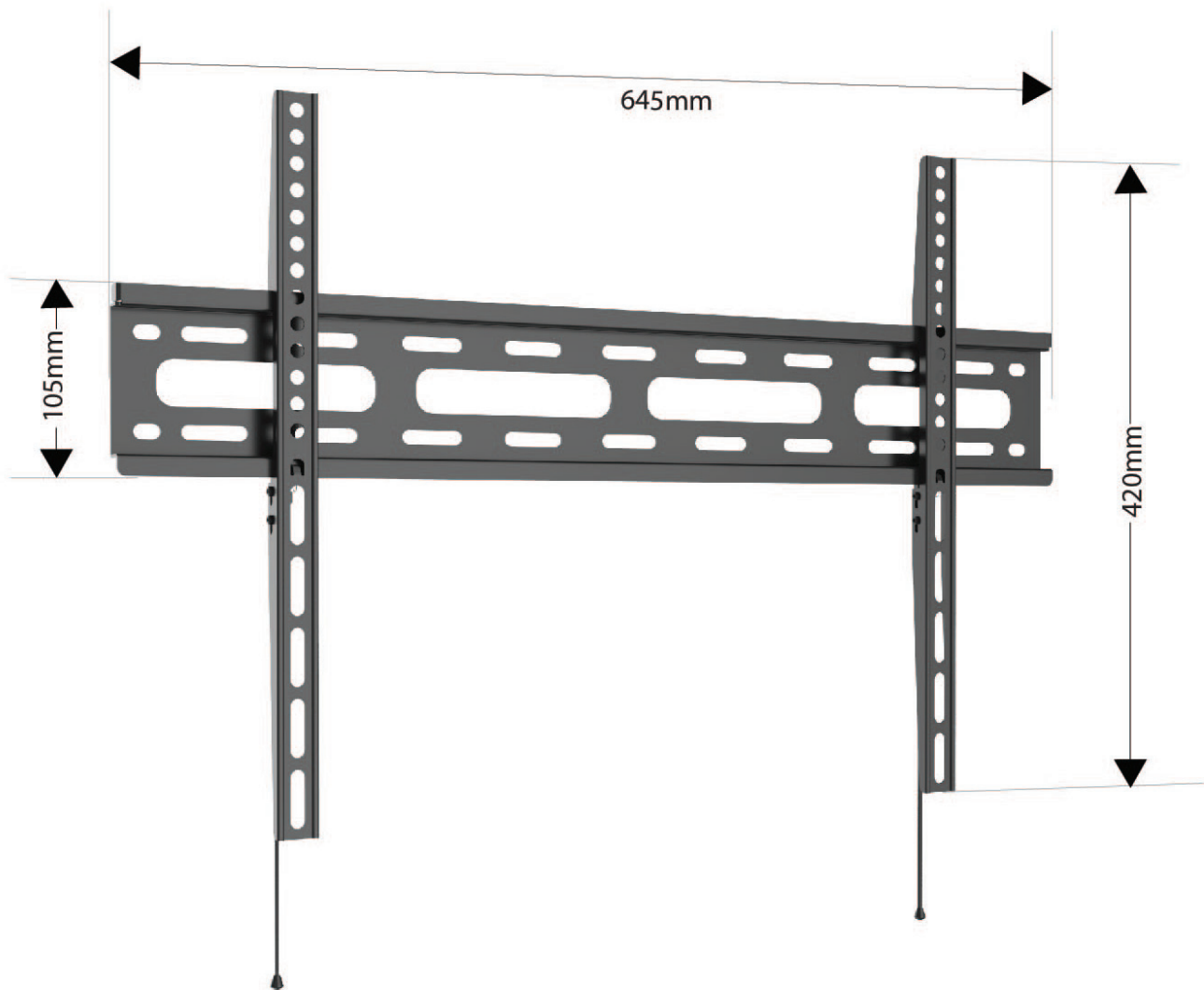

Safety Lock



Super Low Profile



Loctek

AUDIO VISUAL MOUNTS



Ceiling Mounts

Loctek ceiling mounts are an ideal mounting solution when mounting two screens back to back.

These ceiling mounts are easy to install, secure, reliable and versatile making the perfect for commercial applications like pubs, clubs, hotels, sports clubs, restaurants etc.

Ceiling Mounts

PSRD703L

36" to 65" Dual Ceiling Tilt Mount Up to 120kg



36"-65"

SCREEN SIZE

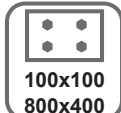

100x100
800x400

VESA



816mm

CEILING DISTANCE



ADJUST



Max
120Kgs

WEIGHT

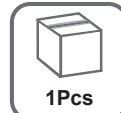

1Pcs

CARTON QTY

An ideal mounting solution when mounting two screens back to back.

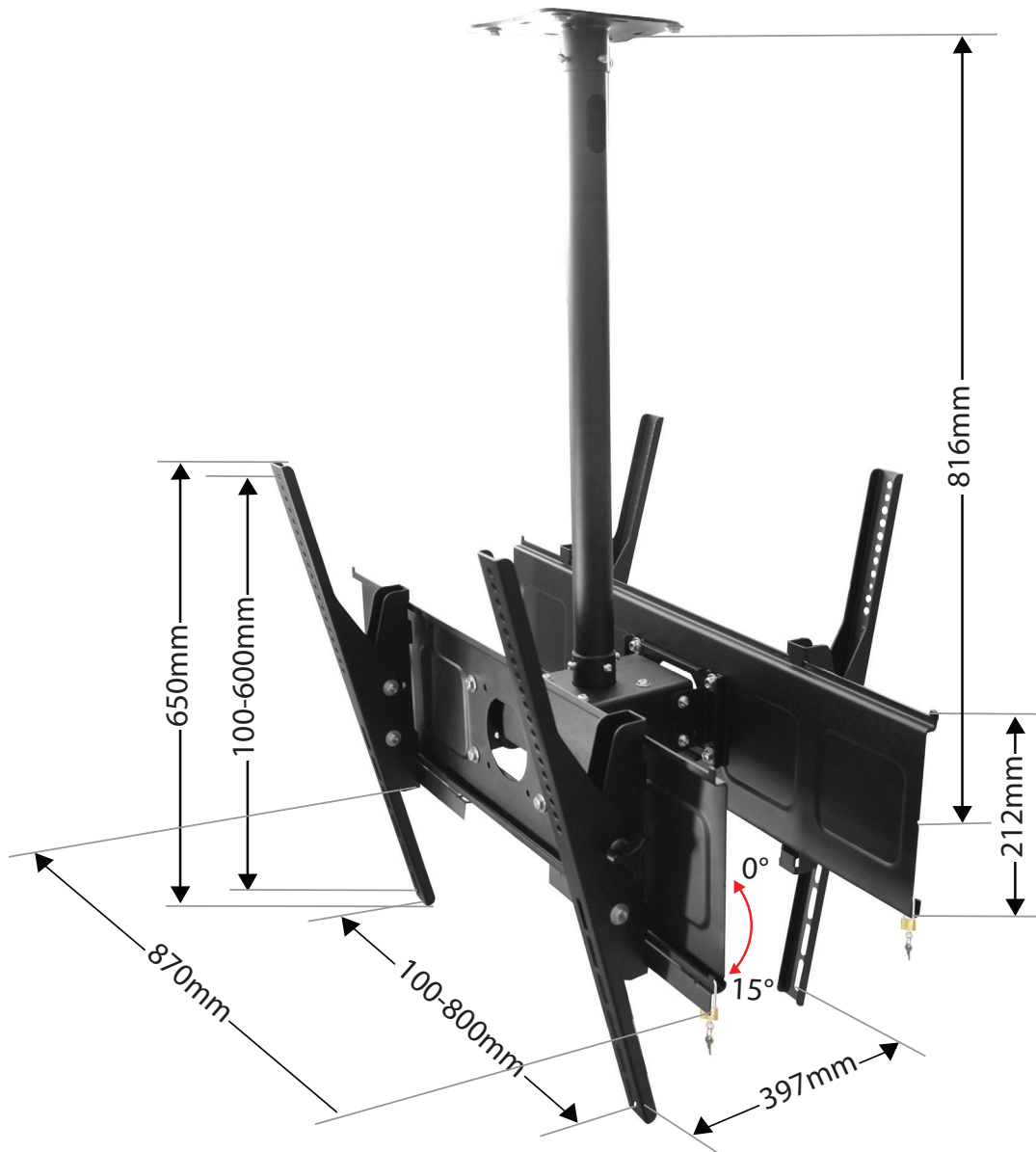

**Integrated
Bubble Level**

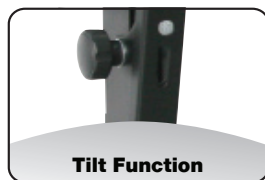

Tilt Function



**Universal
Hole Pattern**



Safety Pad Locks

Ceiling Mounts

PSRD703M 27" to 42" Dual Ceiling Tilt Mount Up to 70kg

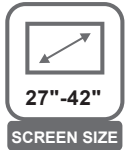

An ideal mounting solution when mounting two screens back to back.

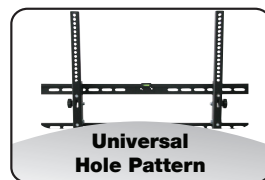
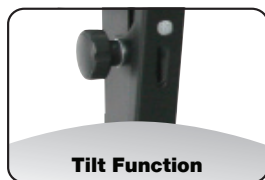
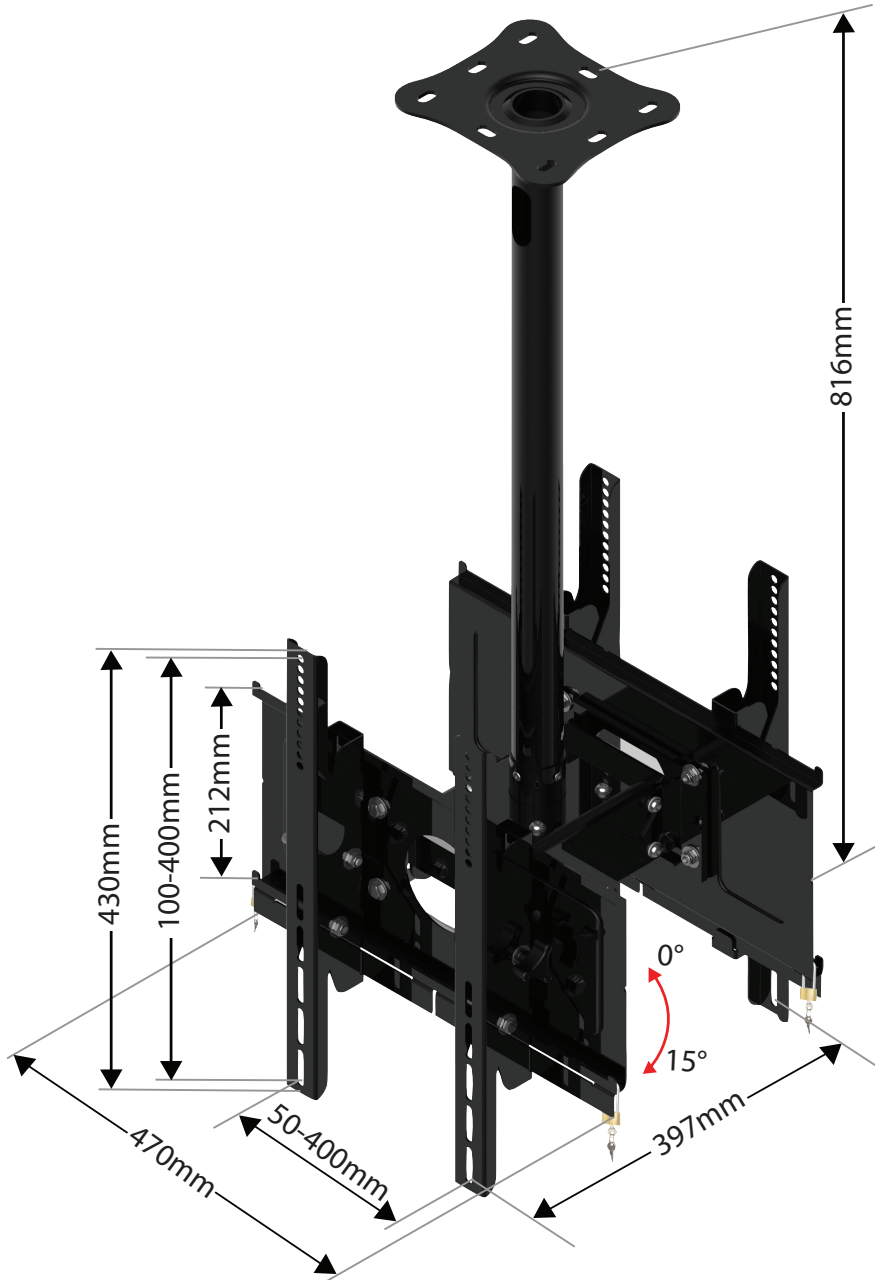



Projector Mounts

The Loctek PMB Series of projector mounts allows you to easily and securely mount your projector to the ceiling. This mount offers a wide range of adjustments with features like Tilt / Roll ± 15 degrees and 360 degree rotation to easily position your projector and secure it to maintain a stable image while viewing. With a weight capacity of 8kg and the option of using the four extending support arms this mount is suitable for most small to medium sized projectors.

Projector Mounts

PMB306

570 - 822mm Ceiling Projector Mount Up to 8kg

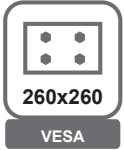

Allows you to easily and securely mount your projector to the ceiling.

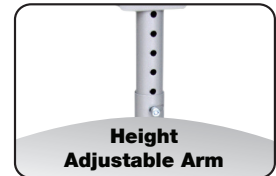
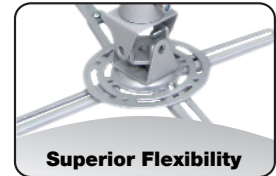
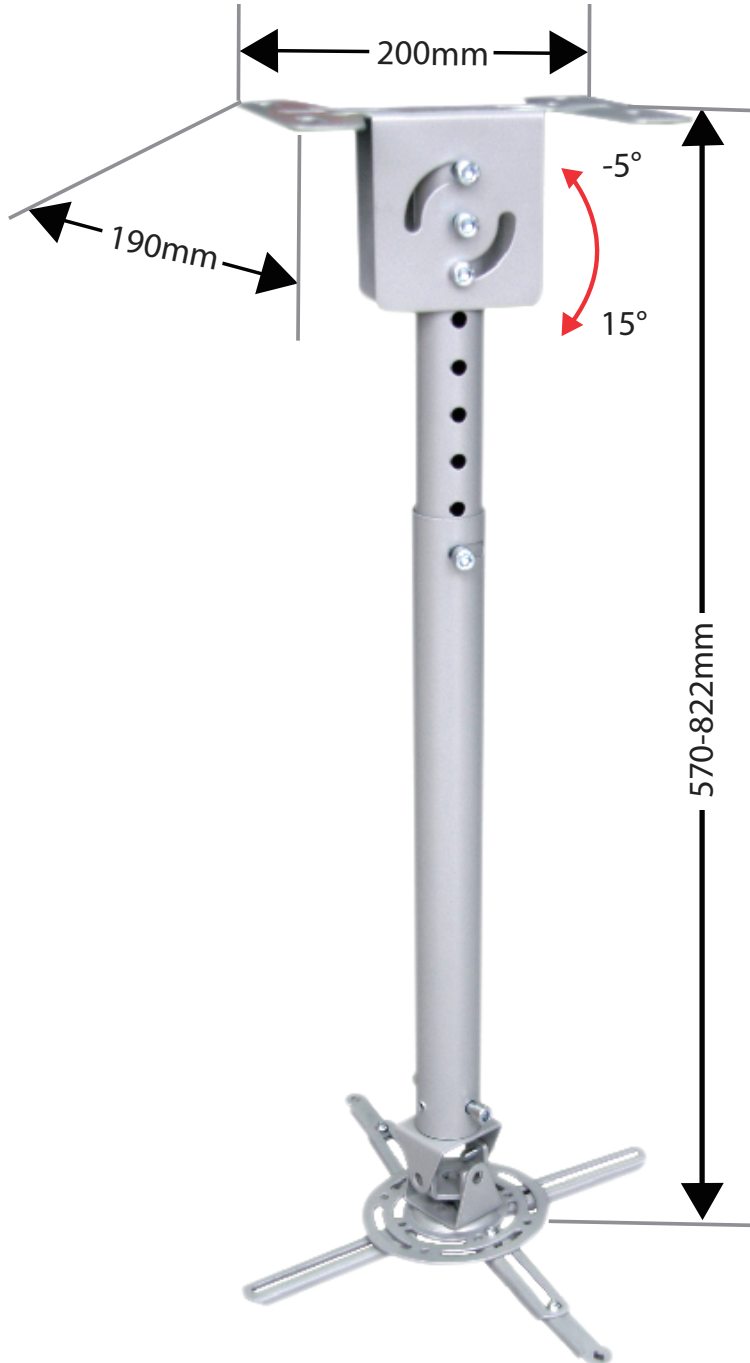

Loctek

AUDIO VISUAL MOUNTS



Desk Top Mounts

Loctek desk top mounts are ideal for the office environment. Eliminate clutter and increase your workspace while adjusting the screen to the perfect viewing angle for comfortable body posture.

Desk Top Mounts

DLB204

Four Screen Dual Arm Desktop Mount Up to 8Kgs



Allows maximum flexibility — extend, tilt, swivel and adjust the height achieving the perfect angle.

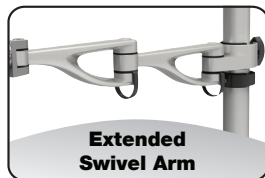
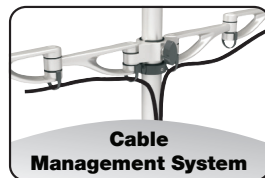
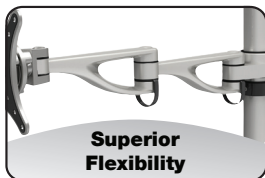
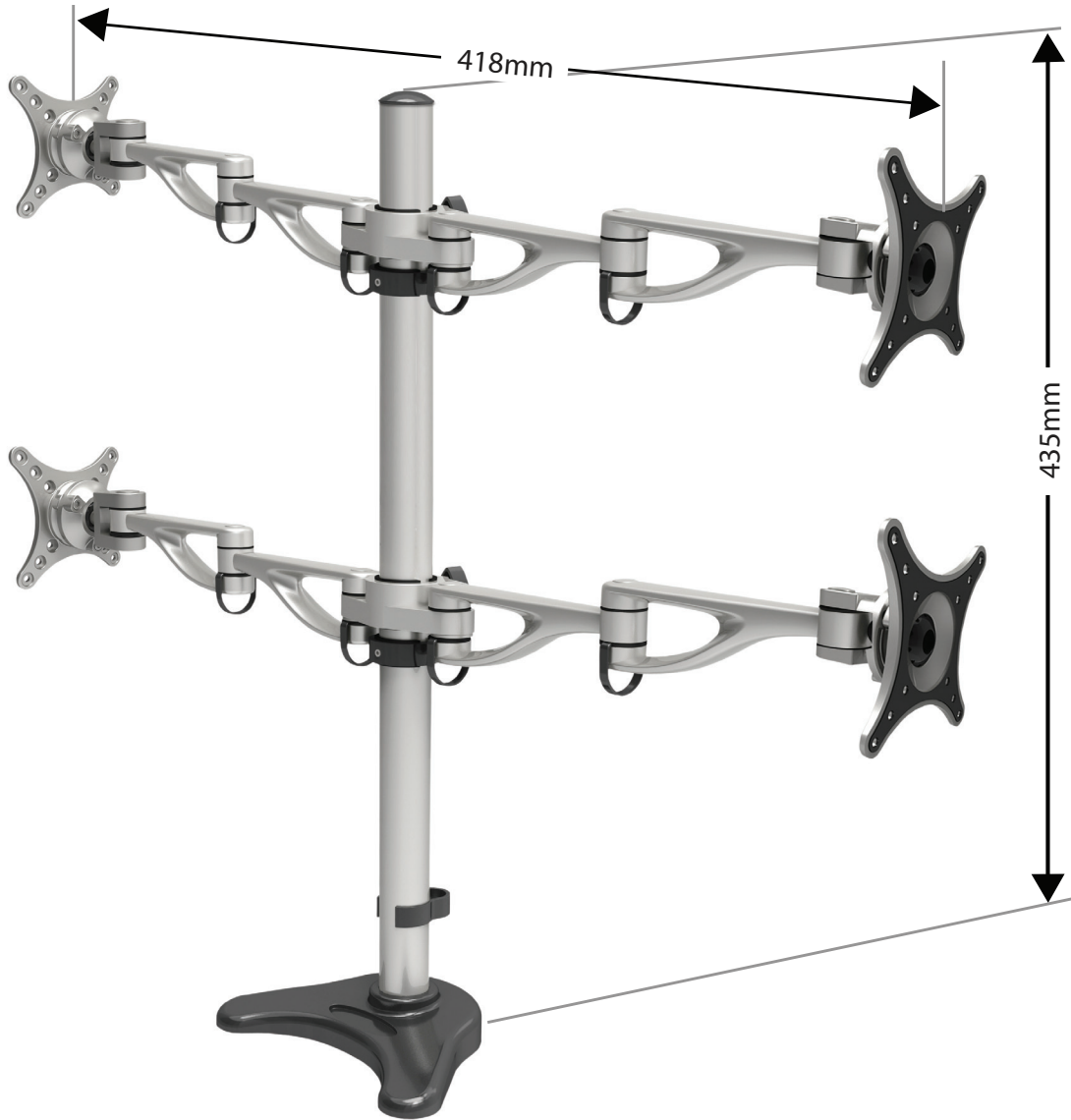

Desk Top Mounts

DLB502W

White Gas Spring Desktop Mount Up to 5kg

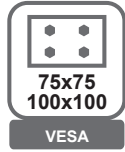

Allows maximum flexibility — extend, tilt, swivel and adjust the height achieving the perfect angle.

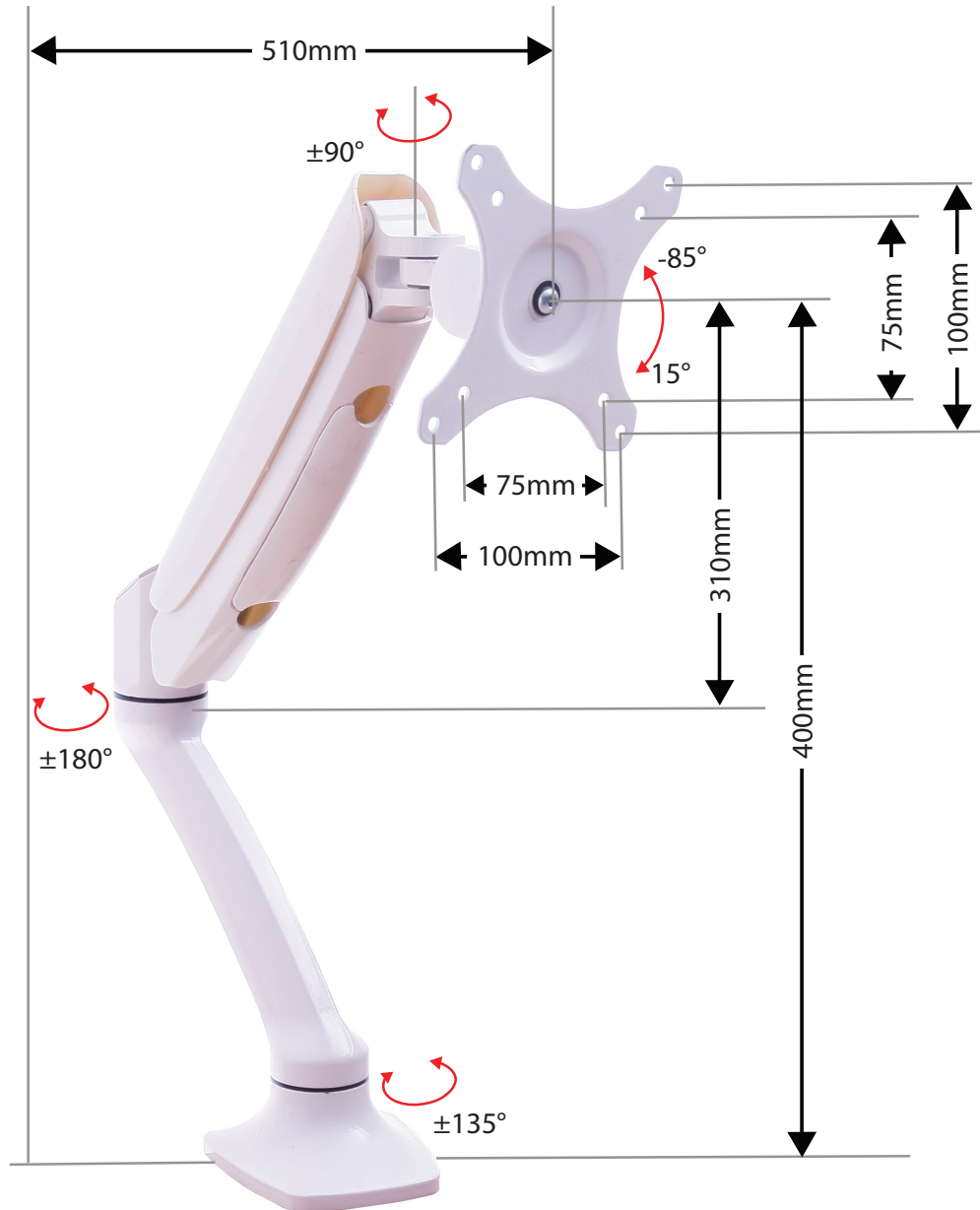

Loctek

AUDIO VISUAL MOUNTS

loctek.com.au

sales@loctek.com.au

t: +61 (3) 9330 3588

f: +61 (3) 9330 3788

74 Barrie Road Tullamarine VIC 3043



Proud Partner

Store Stamp

2023/24